

ProFire Kamado Bravo

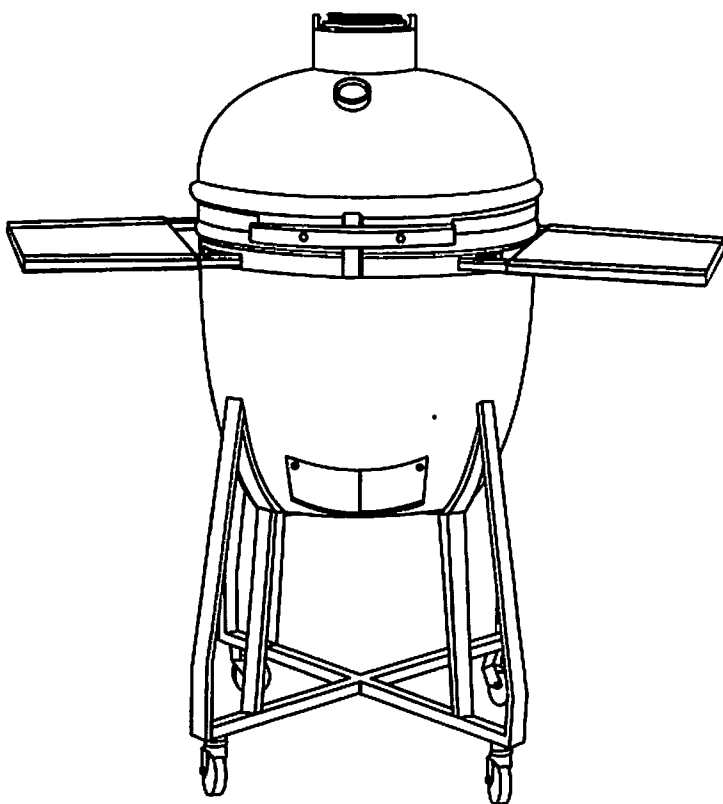

Operating Instructions

Index

1. SafetyPage 1
2. Know your kamado.....Page 2-3
3. Cart Assembly.....Page 4-5
4. Using your kamado.....Page 5
5. Cooking Methods.....Page 6
6. Cleaning and Maintenance.....Page 7

Attention:-

Safety and Maintenance

- When transporting your kamado, never lift it by the hinge. Have at least two individuals hold the bottom and back of the grill. Lower it into your table or metal stand with one hand on the inside of the grill grasping the bottom vent.
- Grill should only be used outdoors in an area where there is adequate clearance for ventilation. Keep the space around your grill clear of hanging tree limbs or other flammable objects.
- Lighter fluid should never be used. For best results, use natural lump charcoal, which is free of tars and other harmful chemicals, so it won't compromise the taste of your food.
- The constant opening and closing of the grill may cause tension in the hinge over time. Make sure to lubricate the moving parts inside the hinge at least twice a year to keep the mechanism operating smoothly.
- To ensure your lid stays securely held by the hinge bands, frequently check and tighten the band bolts using an open end wrench.
- It's important to always take caution when opening the grill after the top and bottom vents have been completely closed to extinguish the fire. In this state the hot coals are suffocated of oxygen and a rush of air could cause a flashback. Lift the lid only slightly at first to allow built up heat and steam to escape. Then proceed.
- When fueled with natural lump charcoal, Kamados produce very little Ash. However, allowing too much excess ash in the ash trap to accumulate will suffocate the charcoal and impede air flow. Occasionally check the ash trap and remove excess ash with the recommended ash tool by simply raking the cooled remains out of the bottom vent door and into a receptacle for disposal. Make sure the rock grate air holes are kept open for maximum air flow.
- Unlike metal grills, the ceramic body won't scald the skin if briefly touched when hot. However, as with any HOT item, be sure to use caution when cooking and keep children away.
- Your kamado Bravo is self Cleaning. Simply heat your grill to around 500°F to incinerate food and other debris within the grill. When necessary, use a non-abrasive tool to clean the cooking grids. Never use overly abrasive instruments to clean the grids. For the grill's outer surface, use a damp cloth to wipe away dust as needed.

Know Your Kamado

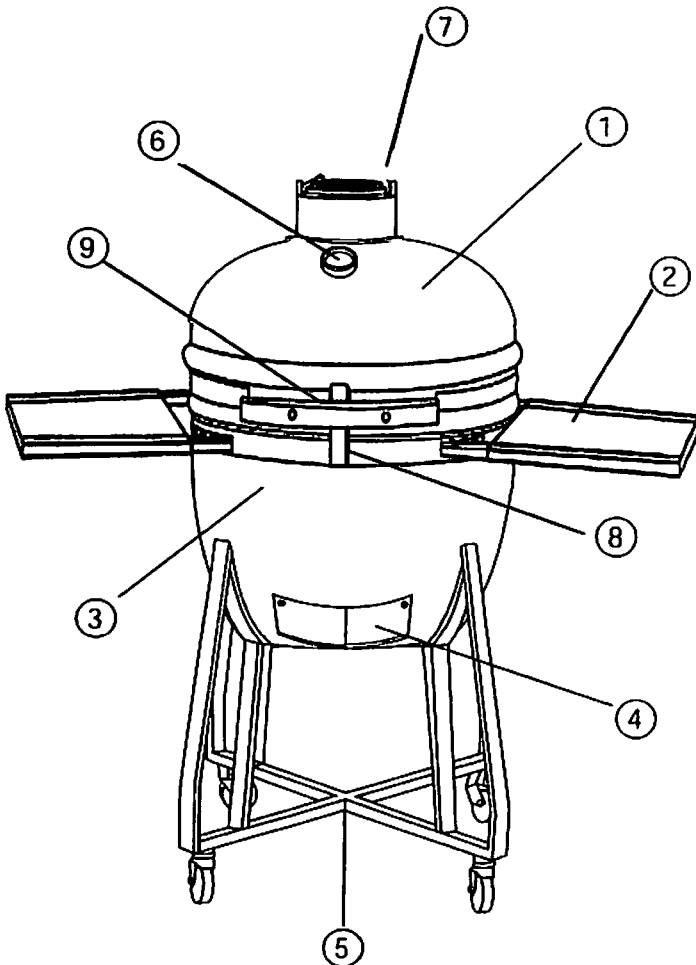

- | | |
|----------------------|-----------------|
| 1. Dome Lid | 6. Thermometer |
| 2. Fold-down Shelves | 7. Top vent |
| 3. Main Body | 8. Lid Dampener |
| 4. Bottom vent | 9. Lid Handle |
| 5. Cart | |

Grill Interior

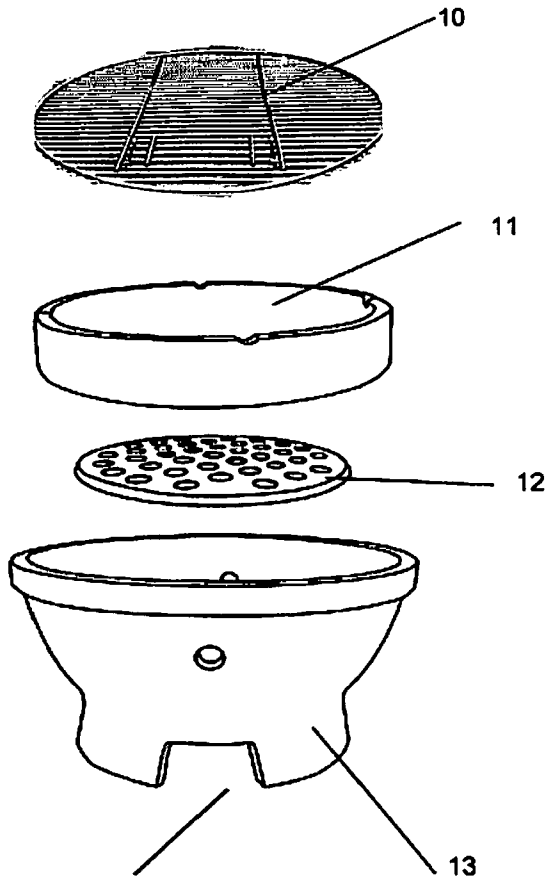

Note:

When the fire box is placed into
The lower grill body, make sure
This cutout is aligned with the
Air vent door opening.

- 10. Cooking grid
- 11. Upper ring
- 12. Charcoal plate
- 13. Firebox

Cart Assembly

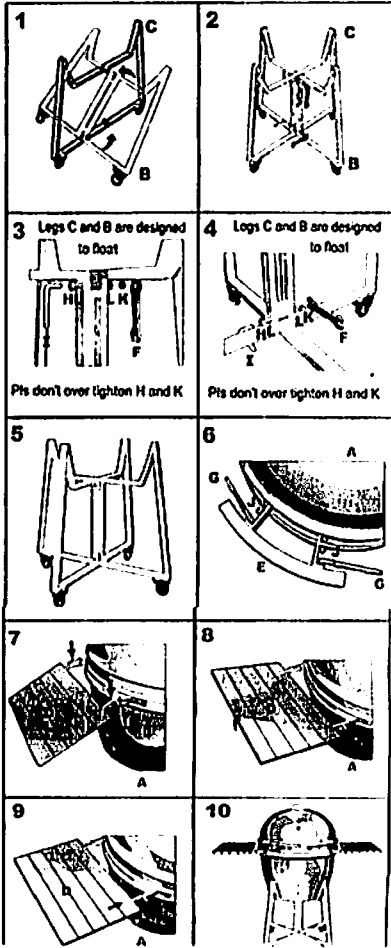
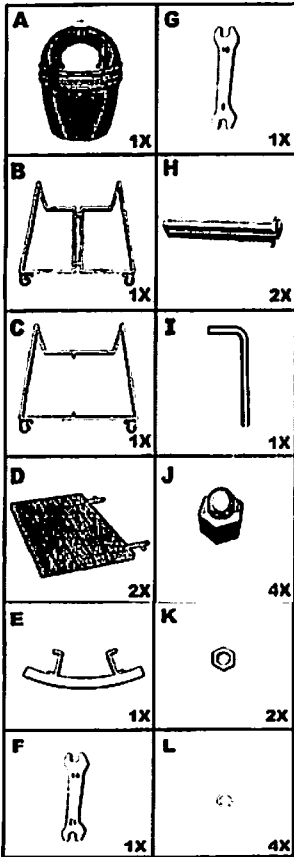

Cart Assy. Continued.

To place the grill on the cart please follows these steps:

1. Remove all of the items that inside of the grill to make lifting easier.
2. Use a minimum of two people when lifting the grill onto the cart. Place one of your hands in the bottom vent of the grill and the other under the grill. Lifting by the hinge or the side tables could result in injury and will void the warranty if damage occurs.
3. Place the grill with the vent facing the front of the cart allowing for the vent to open and close without any interruption. Make sure the firebox cutout is aligned with the air vent door on the lower kamado body.
4. When the grill is securely placed on the cart add the firebox charcoal plate and upper ring inside of the grill in that order.

Using your kamado

Fill half of the firebox when preparing small portions and grilling at lower temperature. When cooking larger portions, fill the firebox within 3" of the top, higher temperatures, and longer cooking times. When filling the firebox only use natural lump charcoal.

Lighting the charcoal

Open the top and bottom vents so they are fully open, place paper or lighter cubes at the bottom of the grill. Place the lump charcoal on top of the charcoal and make a pyramid. Light the paper/cubes with a grill lighter or an electric starter until it becomes lit. Once the charcoal becomes gray, spread the charcoal across the bottom to evenly heat. You may also use a chimney starter to start the charcoal. Once your charcoal has started insert the cooking grid onto the upper ring, and close the lid. Never use lighter fluid because a chemical taste will permeate in the grill for its entire life affecting the flavor of your food.







Cleaning and Removing Ash

After the initial use of the grill ash will begin to generate. Use the optional ash tool to stir the charcoal inside of the grill. Any loose particles within the grill will fall through the charcoal plate. Remove the ash from the grill by inserting the ash tool into the bottom vent and scooping the ash out of door. Be sure to make sure the air holes in the bottom charcoal plate is clear so optimum airflow is possible.

Controlling the temperature

Once the grill approaches the desired temperature adjust the vents to reach your desired temperature. This may take some time to perfect but below is a vent chart depicting temperature control. Please note that the amount of charcoal, outdoor temperature and wind will slightly change this chart.

A general guide to temperatures*:

Temp/Setting	Bottom Vent position	Top Vent position
Low (225°F-275°F)		
Med (325°F-425°F)		
Hi (500°F-plus)		



Cooking Methods

The kamado is great for both direct and indirect cooking. To use the direct cooking method place the cooking grid directly on the upper ring. This configuration will cook your food similar to a gas or charcoal kettle grill. This method works best for cooking items like burgers, hot dogs and steaks.

To use the indirect cooking method place the plate setter on top of the upper ring and place the cooking grid onto the plate setter. This will allow the grill to cook food more evenly similar to how an oven cooks. Indirect cooking is preferred method of cooking items low and slow like ribs and roasts.

Another advantage of the kamado is the ability to smoke foods. To smoke foods place a handful or two of soaked wood chips or chunks on top of the lit charcoal and set up your grill for indirect cooking. The more the wood that is placed on the charcoal the smokier the flavor the food will be.

Grilling, Searing, Smoking Guidelines

The following times and temperatures are approximate and should only be used as a guideline. Always use a meat thermometer to determine whether or not your meat is fully cooked.

Slow cooking/ Smoking 225°F-275°F

Whole Chicken	3-4hrs
Ribs	3-5hrs
Boston Butt	9+hrs
Turkey	2-4hrs
Ham	2-5hrs

Grilling 325°F-425°F

Shrimp	5-8min
Fish	15-20min
Pork Tenderloin	15-30min
Whole Chicken	1-1.5hrs

Searing 500°F+

Steak	5-8min
Hamburger	6-10 min
Pork Chops	6-10min

After Cooking

Once the grill has finished cooking, close the top and bottom vents to suffocate the flame. After the charcoal is no longer lit open the lid and let cool. Place the optional cover on the grill once the grill becomes cool to the touch. Most times the remaining charcoal can be used for the next cook out.

Cleaning

The Kamado grill is self cleaning. Just turn the grill up to 500°F for half an hour and your grill will incinerate all of the food and debris. Never place water or any detergents on the inside of the grill. If water or detergents are used the grill could possibly crack. At times it may be necessary to use a non-abrasive cleaner on the cooking grids, otherwise a brass bristled brush will suffice. Don't clean the grids when they are in the grill. To clean on the outer surface wait until the grill is cool and use a damp cloth with a mild detergent.

Maintenance

Tighten the bands and oil the hinge 2 times a year.

ProFire Kamado Bravo Warranty

The parts listed below are warranted for the time period specified and with the following qualifications.

- 20 Years: Ceramic components including lid, bottom, firebox and fire ring
- 10 Years: Cast aluminum vent cap & stainless steel parts including: bands, hinge, hardware, ash door, stand and cooking grid.
(*Warranty is for rust thru and loss of structural integrity.*)
- 1 Year: All other components including charcoal grate, shelves, casters, handle, thermometer and gaskets.

ProFire warrants to the original purchaser of the Bravo grill that it is free of defects in material and workmanship for the above periods.

This warranty shall be limited to the repair or replacement of any part which under normal residential use and maintenance ProFire determines after reasonable examination to be defective. ProFire shall replace parts found defective with equivalent parts and shall ship such parts at the purchaser's expense to the purchaser's shipping address.

Grills in a commercial, community or multi tenant applications will have a 1 year warranty on all parts.

What is not covered:

This warranty does not apply to freight, labor or any other cost associated with the service or repair of the grill.

This does not cover damage due to the forces of nature, natural disasters, theft, vandalism, operator error, improper use, assembly, maintenance or installation, over firing, abuse or accidental damage.

This warranty does not cover damage from normal wear and tear from use of the product such as the ceramic fading, chipping, scratching or other changes in appearance that do not affect the performance of the grill.

Bill of sale, cancelled check or payment record should be kept to verify purchase date and validate warranty.

TO THE MAXIMUM EXTENT PROVIDED BY STATE AND FEDERAL LAW, THIS LIMITED WARRANTY IS IN LIEU OF ALL OTHER WARRANTIES, EXPRESS OR IMPLIED AND SPECIALLY EXCLUDES THE FOLLOWING:

WARRANTY TO ANYONE OTHER THAN THE ORIGINAL PURCHASER; WARRANTIES OF MERCHANTABILITY AND FITNESS FOR A PARTICULAR PURPOSE; ANY AND ALL LIABILITY FOR INCIDENTAL, SPECIAL OR CONSEQUENTIAL DAMAGES, EXCEPT WHERE SUCH EXCLUSION IS EXPRESSLY PROHIBITED BY LAWS OF THE STATE OR THE ORIGINAL PURCHASER'S RESIDENCE.